

AP Physics 1- Kinematics Practice Problems

[Solutions Video]

(CB Unit 1; CB Topics 1.1-1.2)

FACT: Kinematics is the branch of Newtonian mechanics concerned with the motion of objects without reference to the forces that cause the motion.

FACT: Displacement is the straight-line distance between the initial and final points and the symbol for displacement is Δx , where Δ means “change in” and x means “position” in meters (S.I. units). Displacement is an example of a vector quantity because it has both magnitude and direction. A scalar only has magnitude (e.g., mass does not have a direction).

Q1. A deer walks 1300 meters east to a creek for a drink. The deer then walks west for 500 meters to a berry patch for dinner, before running 300 meters west when startled by an exploding stoichiometric rocket. What distance did the deer travel? What is the deer’s displacement?

Q2. A rock is thrown straight upward from the edge of a 30 meter cliff, rising 10 meters and falling to the base of the cliff. Find the displacement and the distance of the rock

FACT: An object’s displacement vector is drawn as an arrow from the object’s initial position, regardless of the actual path followed between the two points. Vectors can be added together using the tip-to-tail method along with trigonometry.

Q3. Sophia walks 90 m due east and then 50 m due north. What is her displacement from her starting point?

FACT: Velocity (v) is the change in position divided by the change in time. Equation is: $\frac{\Delta x}{\Delta t}$ and velocity has both magnitude and direction.

Q4. A tourist being chased by an angry bear is running in a straight line towards his 4Runner at 4 m/s. The vehicle is a distance, d , away. The bear is 26 m behind the tourist and running at 6 m/s. The tourist arrives safely at his 4Runner. What is the maximum possible value for d ?

FACT: Acceleration is the change in velocity divided by the change in time. Acceleration, just like displacement and velocity, has both magnitude and direction. The equation is equation is: $\frac{\Delta v}{\Delta t}$

Q5. A school bus is driving at 50 km/hr south on Villa Rica Hwy when a squirrel runs out in front of the bus. The bus driver applies the brakes coming to a complete stop in 2.5 seconds. What was the acceleration of the school bus?

Q6. Sophia is riding her tricycle at -4.5 km/hr when she begins pedaling faster to cause a constant acceleration. If, after 5.0 seconds, the tricycle is moving at -6.0 km/hr, what was the acceleration of the tricycle?

Q7. Sophia’s ball is on the back deck and it rolls 60 cm to the edge, drops 40 cm and continues to roll through the grass and stops 80 cm from the edge of the deck. What is the magnitude of the ball’s net displacement?

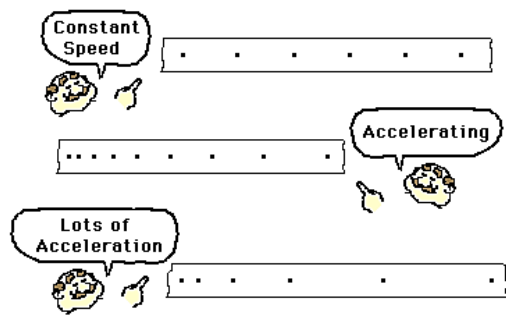

FACT: Particle diagrams or ticker tapes or dot diagrams show the position or displacement of an object at evenly spaced intervals. Study the particle diagrams to the right. Try to come up with a scenario that would be representative of each particle diagram.

Q8. For each of the ticker tapes shown below (1.-3.), write a sentence to justify the motion of the object.

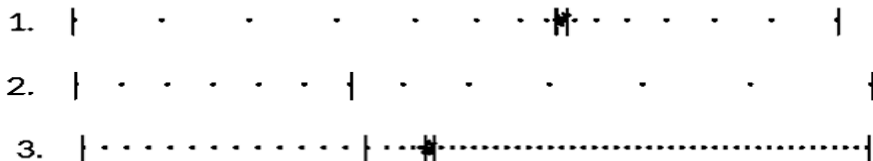

FACT: Information about the motion of objects can also be found using video analysis and frame rates. For an example, please view Flipping Physics (1D motion) podcast #21 about the Apollo 15 mission.

Q9. Use the following video to make measurements that will allow you to calculate the speed of a roller coaster.

<https://www.youtube.com/watch?v=8emTCxG29o8>

FACT: The slope of a position-time graph is the velocity and the slope of a velocity-time graph is the acceleration.

FACT: The area under a velocity-time graph is the displacement; the area under an acceleration-time graph is the change in velocity.

Q10. In addition to this question, please also complete the position time, velocity time, and acceleration time graphs available as separate hand-outs on the left side of the Kinematics webpage. Examine the graph displaying velocity as a function of time. Create the position-time and acceleration-time graphs using the data on the velocity-time graph. Please assume an initial position of zero.

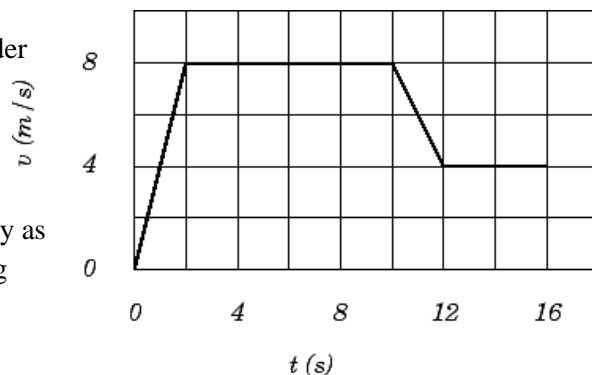

Q11. Examine the velocity-time graph to the right and answer a-c.

- Draw the corresponding position vs. time graph. ($x = 0$ m at $t = 0$)
- What is the object's position at $t = 12$ s?
- Describe a moving object that could have these graphs.

FACT: There are four kinematic equations for uniformly accelerated motion (UAM) and you only need three of the five kinematic variables to solve any given equation. When attempting to solve an equation, never solve a quadratic. If it comes to this, you need to choose another kinematic equation to solve the problem. Here are the equations:

$$v_f = v_i + a\Delta t$$

$$\Delta x = v_i\Delta t + \frac{1}{2}a\Delta t^2$$

$$v_f^2 = v_i^2 + 2a\Delta x$$

$$\Delta x = \frac{1}{2}(v_i + v_f)\Delta t$$

There are 5 variables in the UAM equations:

v_i = velocity initial

v_f = velocity final

a = acceleration

Δx = displacement

Δt = change in time

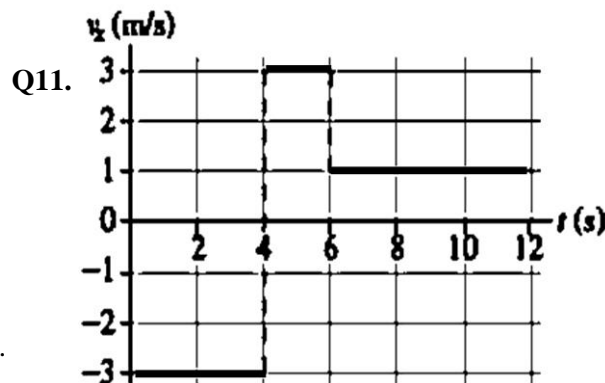

Q12. An object with an initial velocity of 4 m/s moves along a straight axis under constant acceleration. Three seconds later, its velocity is 14 m/s. How far did it travel during this time?

Q13. A car that is initially traveling at 10 m/s accelerates uniformly for 4 seconds at a rate of 2 m/s², in a straight line. How far does the car travel during this time?

Q14. The left ventricle of the heart accelerates blood from rest to a velocity of + 26 cm/s. a). If the displacement of the blood is =2 cm, determine its acceleration in cm/s². b). How much time does the blood take to reach its final destination?

Q15. A cheetah is hunting. Its prey runs for 3.0 seconds at a constant velocity of + 9.0 m/s. Starting from rest, what constant acceleration must the cheetah maintain in order to run the same distance as its prey runs in the same time?

FACT: The x variable for change in horizontal position is often replaced with a y variable for the change in vertical position. This will be especially useful as we move into 2D projectile motion.

Q16. A rock is dropped from a cliff 80 m above the ground. How long does it take to reach the ground?

Q17. A baseball is thrown upward with an initial speed of 20 m/s. How high will it go?

Q18. One second after being thrown straight down, an object is falling with a speed of 20 m/s. How fast will it be falling 2 seconds later? How fast was it initially thrown down?

Q19. Little Johnny is riding his bike at 16 km/hr when he applies the brakes causing the bike to slow down with a constant acceleration. After 1.5 seconds he has traveled 6.0 meters. (a) What was his acceleration and (b) what was his final speed

Q20. A toy car starts from rest and experiences an acceleration of 2 m/s^2 for 3 seconds and then brakes for 1.0 seconds and experiences an acceleration of -2.5 m/s^2 . (a) How fast is the car going at the end of the braking period and (b) how far has it moved?

Q21. A ball is released from rest and has an acceleration of 2 meters per second every second. (a) What is the velocity of the ball at $t = 1, 2, 3, 4$ and 5 seconds? (b) If the initial position of the ball is zero, what is the position of the ball at $t = 1, 2, 3, 4$ and 5 seconds?

Q22. A student drops a bocce ball from a height of 1.5 m above the ground. (a) What is the velocity of the ball right before it strikes the ground? (b) How long did the ball fall?

Q23. Sophia throws a ball of Play-Doh upward and catches it again at the same height that she threw it. If the maximum height the ball achieves above where she threw it is 1.5 meters, (a) how long was the ball not in her hands and, (b) what were the initial and final velocities?

Q24. A student throws a ball straight up and lets it fall to the ground. If the ball leaves his hand 150 cm above the ground and it lands on the ground 2.0 seconds later, to what maximum height did the ball go above the ground?

Q25. You are wearing your rocket pack ($m_{\text{total}} = 75 \text{ kg}$) that accelerates you upward from rest at a constant 8 m/s^2 . While preparing to take pictures of the view, you drop your camera 3.0 seconds after liftoff. Two seconds (2 s) after you drop the camera, (a) what is the camera's velocity, and (b) how far are you from the camera, and (c) create velocity-time graphs

Q26. (vector) A roach crawls 2.0 m East, then turns 35° North of East and scurries for 3.5 m. It then turns and runs another 2.5 m North. What was its total displacement?

Q27. (vector) A spider races 2.0 m West, then turns North and creeps along for 3.0 m. The spider then turns and scampers another 2.0 m SW. What was the spider's total displacement?

FACT: For projectile motion you will need to break the motion into both the X and the Y directions. The only equation in the x direction is $v_x = \Delta x / \Delta t$, therefore there are 3 variables in the x direction: v_x , Δx & Δt . Therefore, you need to know 2 variables in the x direction to find the other 1. In the y direction use the uniformly accelerated motion equations.

FACT: A projectile has no horizontal acceleration and so moves at a constant velocity in the horizontal (x).

FACT: A projectile is in free fall, so its vertical acceleration (a_y) is always -10 m/s per second.

FACT: The vertical displacement of a projectile launched and landing at the same level is always zero.

FACT: The horizontal (x) and vertical (y) motion equations must use the same values for time (t) \therefore it is the vertical component that determines the time of flight. As the angle increases, so does the flight time.

FACT: An object launched at 45° will have the greatest horizontal displacement. Here is a great animation: <http://www.physicsclassroom.com/mmedia/vectors/mr.cfm>. Mathematically, the proof involves calculus or use of the range formula, which are both beyond the scope of this course.

FACT: To find the vertical velocity (v_{oy}) component of a projectile launched at an angle, multiply the velocity by the sine of the angle: $\sin \theta (v_o) = v_{oy}$. To find the horizontal velocity (v_{ox}) component of a projectile launched at an angle, multiply the velocity by the cosine of the angle: $\cos \theta (v_o) = v_{ox}$

FACT: The initial velocity in trajectory motion is equal in magnitude (opposite direction) to the final velocity (air resistance is negligible). Remember this would apply to the instant after launch and the instant before impact. Otherwise, the object is not a projectile.

Q28. An object is projected upward with a 30° launch angle from the ground and an initial speed of 60 m/s. For how many seconds will it be in the air? How far will it travel horizontally? Assume it returns to its original height.

Q29. While in a 4Runner moving at 20 miles per hour, Sophia drops her juice bottle out of the 4Runner and the bottle falls 1.2 m to the ground, miraculously landing in a sewer drain. Part 1). How far in front of the sewer drain did Sophia drop the bottle such that it landed perfectly in the drain? Part 2). What is the final velocity of the bottle right before it enters the drain?

Q30. Two balls are launched upward from the same spot at different angles with respect to the ground. Both balls rise to the same maximum height. Ball A; however, follows a trajectory that has a greater range than ball B. Ignoring air resistance, decide which ball, if either, has the greater launch velocity? Give your reason or prove mathematically.

Q31. A 30° incline sits on a table that is 1.1 m above the base of a small car as shown in the image to the right. A ball rolls off the incline with a velocity of 2 m/s. How far does the ball travel across the room before reaching the car on floor?

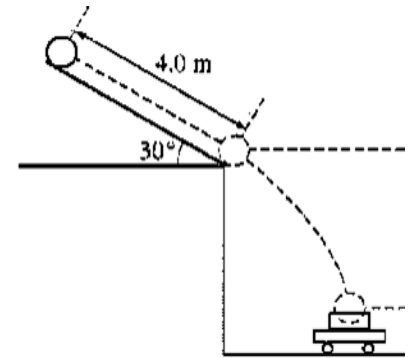

FACT: All motion is relative and dependent on the frame of reference. In order to determine an object's velocity, you need to state the reference frame. For most problems the reference frame is Earth, but that is not always the case. For example in the next problem, we would call the velocity of the velocity of the turtle with respect to the eagle V_{TE} and the velocity of the turtle with respect to the ground V_{TG} , lastly we would call the velocity of the eagle with respect to the ground V_{EG} .

Q32. An eagle flies at constant velocity horizontally across the sky, carrying a turtle in its talons. The eagle releases the turtle while in flight. From the eagle's perspective, the turtle falls vertically with speed v_1 . From an observer on the ground's perspective, at a particular instant the turtle falls at an angle with speed v_2 . What is the speed of the eagle with respect to an observer on the ground? Express your answer in terms of V_1 and V_2 .

Q33. An airplane flies at 250 m/s to the east with respect to the air. The air is moving 15 m/s east with respect to the ground. Find the velocity of the plane with respect to the ground.

Q34. A train travels east toward Chicago at 80 km/hr. A man on the train runs from the front of the train toward the rear of the train at 10 km/hr. As he runs, he carries a plate of fruit with him. He notices a giant spider on the plate and throws the plate away from him (toward the rear of the train) at 20 km/hr. The startled spider jumps toward the man at 5 km/hr. The instant after the spider jumps toward the man, how fast is the spider approaching Chicago?

Q35. A boat takes 3.0 h to travel 30 km down a river, then 5.0 h to return. How fast is the river flowing?