

**AP Physics 1- Torque, Rotational Inertia, and Angular Momentum Practice Problems**

**FACT:** The center of mass of a system of objects obeys Newton’s second law-  $F = Ma_{cm}$ . Usually the location of the center of mass (cm) is obvious, but for several objects is expressed as:  $Mx_{cm} = m_1x_1 + m_2x_2 + m_3x_3$ , where  $M$  is the sum of the masses in the expression. In some cases the center of mass is not located on the body of the object. When an object or system rotates, it will usually rotate around its center of mass. Expect 1-2 questions covering this topic on the AP Exam.

**Q1.** A 59-kg woman and a 71-kg man sit on a seesaw, 3.5 m long. Where is their center of mass?

**Q2.** A fisherman in a boat catches a great white shark with a harpoon. The shark struggles for a while and then becomes limp when at a distance of 300 m from the boat. The fisherman pulls the shark by the rope attached to the harpoon. During this operation, the boat (initially at rest) moves 45 m in the direction of the shark. The mass of the boat is 5400 kg. What is the mass of the shark? Pretend that the water exerts no friction.

**Q3.** A 70-kg man is standing on the end of a 250-kg log that is floating in the water. Both the and the log are at rest, and the log is 3.0 m long. If the man walks to the other end of the log, how far will the log move in the water? Ignore any forces exerted on the log by the water.

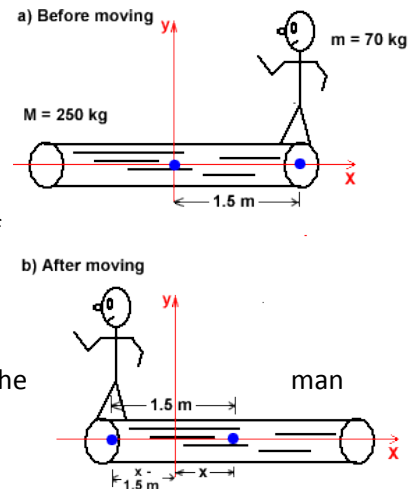

**FACT:** Torque ( $T$ ) is a force that causes an object to turn or rotate. It is a measure of a force’s ability to cause an object to accelerate rotationally. If an object is initially at rest, and then starts to spin, something must have exerted a net torque. If an object is initially spinning, it would require a net torque to stop spinning.

**FACT:** We use sine for torque problems because the torque is a perpendicular force causing an angular acceleration. By definition, the cross product of the force and the moment arm (lever arm, line of action) is the torque. The units for torque are N.m, which is not referred to as a Joule. Notice that  $\sin(90) = 1$ . Recall we used cosine in work problems because the force applied resulting in work is directly correlated with the displacement of the object. In this case,  $\cos(180) = -1$ . Please study the diagrams below and note that  $T = Fr \sin \theta = r_{\perp}F = rF \sin \theta = F_{\perp}r$ . The lever arm is the perpendicular distance from the axis of rotation to the point where the force is applied. You can also think of torque as the component of the force perpendicular to the lever arm multiplied by the distance ( $r$ ).

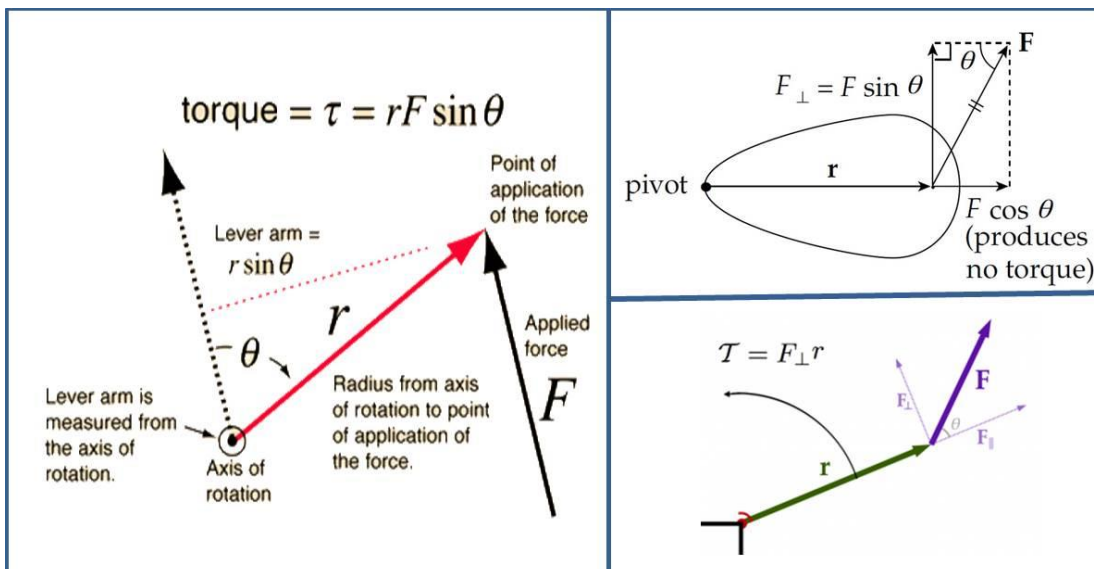

**Q4:** A captain of a ship turns the stirring wheel by applying a 20 N torque. If he applies the force at a radius of 0.2 m from the axis of rotation, at an angle of 80 degrees to the line of action (moment arm), what torque does he apply?

**Q5:** A mechanic tightens the lugs on a tire by applying a torque of 110 Nm at an angle of 90 degrees to the moment arm. What force is applied if the wrench is 0.4 m long? What is the minimum length if the wrench if the mechanic is only capable of applying a force of 200N?

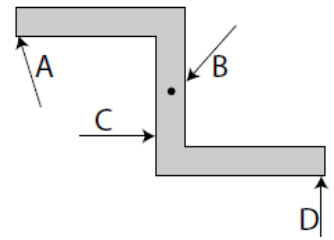

**Q6.** A constant force  $F$  is applied for five seconds at various points of the object, as shown in the diagram. Rank the magnitude of the torque exerted by the force on the object about an axle located at the center of mass from smallest to largest.

**Q7.** A student pulls down on a small modified Atwood machine with a force of 30 N, as shown in the diagram. What is the torque of this force?

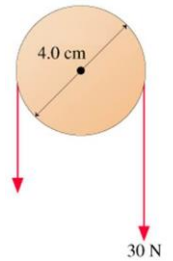

**FACT:** An object will not rotate if the net torque ( $\Sigma T$ ) is equal to zero. This is known as rotational equilibrium.

**Q8.** A 15-kg box sits on a lever arm at a distance of 5 meters from the axis of rotation. What distance must a second 10-kg box sit to create a clockwise moment that will result in a net torque of zero? What would occur if the moment arm of the second box was 8 m?



**Q9.** Forces are applied along various points on a lever arm as shown. Calculate the net torque and describe the resulting motion of the lever. Determine the force and distance from the axis of rotation that would result in a net moment (torque) of zero.

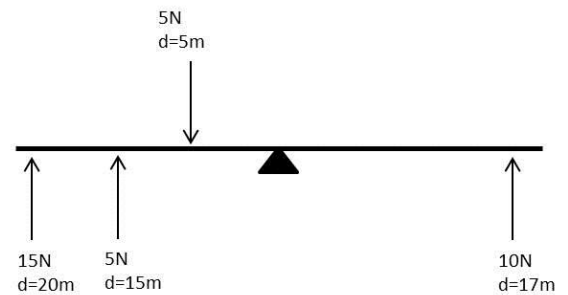

**FACT:** In torque problems with a large extended object (table, bridge, pole, ladder) do not forget that the lever arm itself will have a mass and a center of mass (cm). It is acceptable to assume the object's weight is all hanging from the cm.

**Q10.** A 3-kg Academy sign is hung from a 1-kg, 4-meter horizontal pole as shown. The sign is hung 1-meter from the right side. A wire is attached to prevent the sign from rotating. Find the tension in the wire.

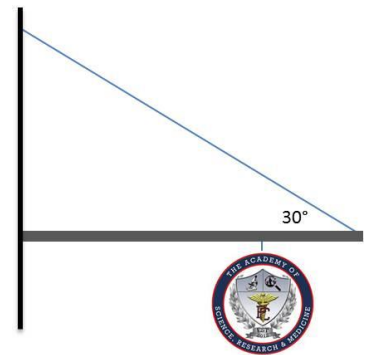

**FACT:** In table/bridge problems the fulcrum (pivot point) is arbitrary because the object is not rotating. Choose one of the supports as the fulcrum, which means that point now has zero torque ( $r = 0$ ).

**Q11.** A table has an 18-kg object placed 0.8 meters from the left table leg. The mass of the table top is 6-kg. What is the force exerted on each leg? What would occur if the left leg broke?

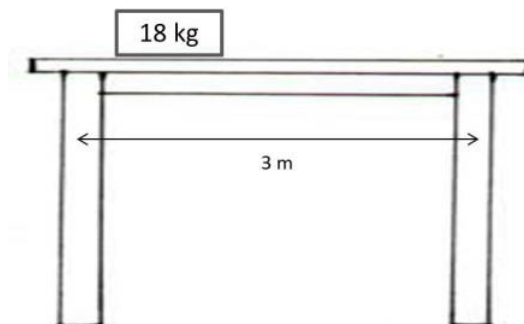

**Q12:** A 50-kg box is hung from a 5-meter long, 200-kg horizontal pole as shown. A wire is attached to prevent the sign from rotating. The box and wire attach at the right end of the pole as shown below. Find the tension in the wire.

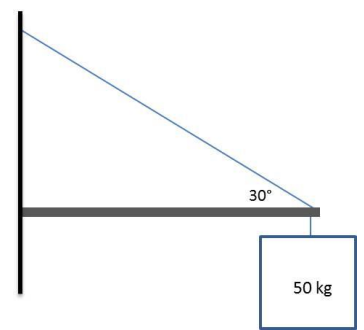

**FACT:** A system is in static equilibrium when the sum of the forces and the sum of the torque are zero. We will also explore the idea of static equilibrium in an AP Investigation for this unit. This concept can be applied in what I call a “ladder problem” and you will encounter one of these problems on the AP Exam. In ladder problems, it is easier to use the perpendicular distance ( $r_{\perp}$ ) to find the torque. You can still use the perpendicular component of force ( $F_{\perp}$ ).

**Q13.** A 5 meter, 200N-long ladder rests against a wall. The ladders center of mass is 3.0 meters up the ladder. The coefficient of friction on the ground is 0.30. How far along the ladder can a 75-kg person climb before it slips? The angle between the ladder and ground is 56 degrees.

**Q14:** Examine the diagram of a bear on a pole. The string (T) can hold a total of 900 N. Can the bear reach the 80-N basket of food without the string breaking? The total distance out to the food is 6-m.

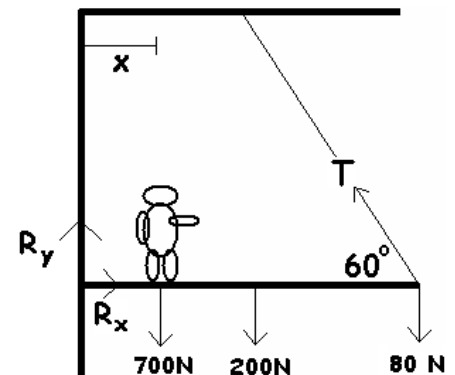

**FACT:** The rotational equivalent of Newton’s Second Law is expressed as,  $\Sigma T = I\alpha$ , where  $I$  is the rotational inertia and  $\alpha$  is the angular acceleration. The rotational inertia is sometimes referred to as the moment of inertia. Recall from translational dynamics that the larger the force, the greater the acceleration. Also, recall that the larger the mass, the smaller the acceleration (inversely proportional). This also holds true for rotational dynamics ( $\Sigma T = I\alpha$ ); the rotational inertia is inversely related to the angular acceleration.

**FACT:** Objects that have most of their mass near their axis of rotation have a small rotational inertia, while objects that have more mass farther from the axis of rotation have larger rotational inertias. The AP exam will provide with the formula for rotational inertias, as they are derived using calculus. Here are some of the common formulas:

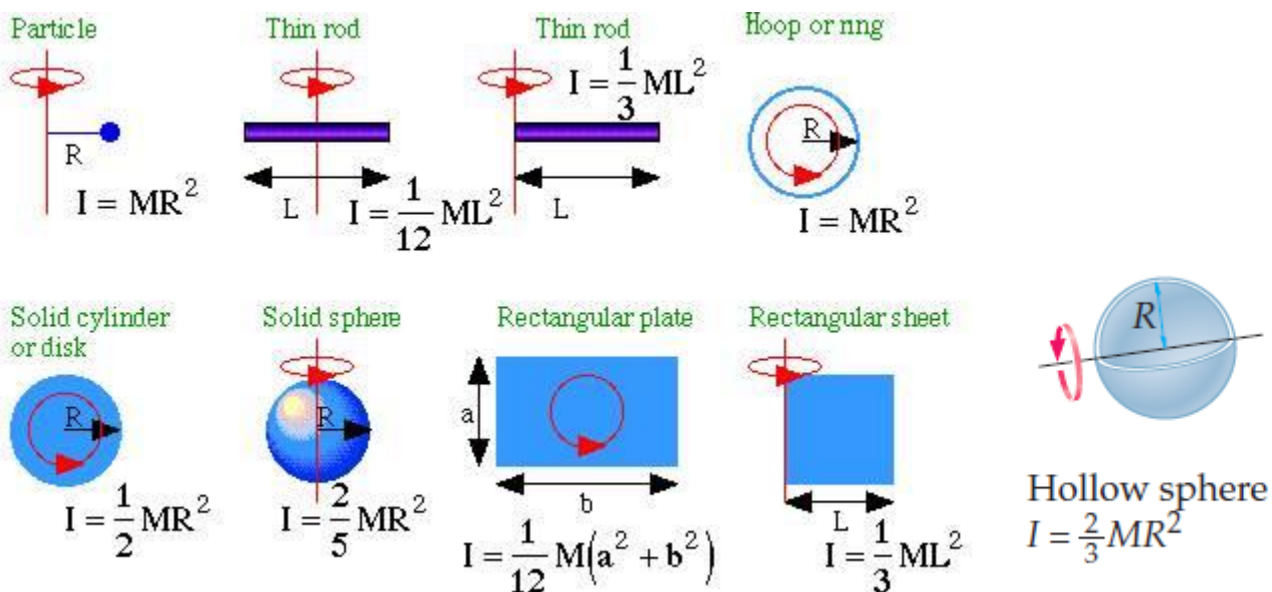

**Q15.** An object with uniform mass density is rotated about an axle, which may be in position A, B, C, or D. Rank the object's rotational inertia from smallest to largest based on the axle position.

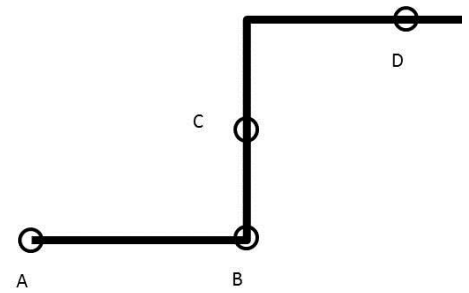

**FACT:** For a system of objects you will need to add the rotational inertia of each object to find the rotational inertia of a system. For point masses, this can be expressed mathematically as  $I = \sum mr^2$ .

**Q16.** Find the rotational inertia ( $I$ ) of two 5-kg bowling balls joined by a meter long rod of negligible mass when rotated about the center of the rod. Compare this to the  $I$  of the object when rotated about one of the masses. The dot indicates the axis.

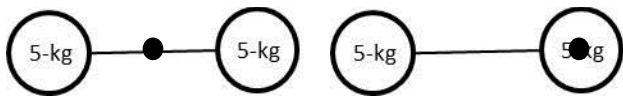

**Q17.** What is the angular acceleration experienced by a uniform solid disc of mass 2-kg and radius 0.1 m when a net torque of 10 N.m is applied? Assume the disc spins about its center.

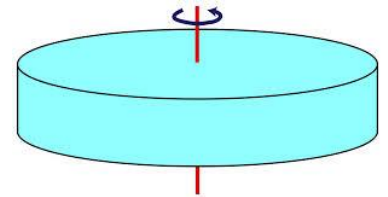

**Q18.** Given the net torque of the system, find the angular acceleration for the system of three particle masses. The radius from the axis of rotation is 12 m and the masses are equidistant. Assuming a constant acceleration, what would the angular velocity be after 5 seconds? How many revolutions will be completed after 20 seconds with constant acceleration?

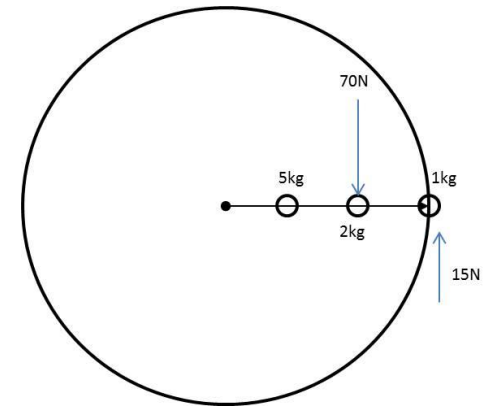

**FACT:** The parallel axis theorem is given as:  $I_{pa} = I_{cm} + Md^2$ . This can be used to find the rotational inertia of an object when the axis of rotation is not in the center of mass (cm). The equation says that the rotational inertia around a parallel axis equals the rotational inertia at the center of mass plus the total mass of the object multiplied by the distance between the two axes squared. This equation is not provided on the AP Exam, but it could prove to be very useful and has been applicable to the exam in the past.

**Q19.** What is the rotational inertia ( $I$ ) of the disk shown with a radius,  $R = 4$  meters and a mass of 2 kg? The same disk is rotated around an axis that is 0.5 meters from the center of the disk. What is the new rotational inertia ( $I$ ) of the disk? What would the rotational inertia be if the disk axis was 3.75 meters from the center?

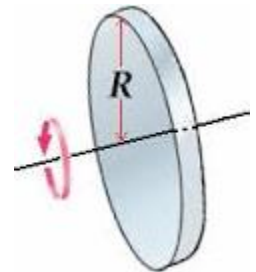

**Q20.** A hoop with a radius of 0.75 meters is rotated about an axis 0.5 meters from the center of mass. The hoop weighs 2 kg. What is the rotational inertia of the hoop?

**Q21.** To the right are four identical figure L's, which are constructed from two rods of equal lengths and masses. For each figure, a different axis of rotation is indicated by the small circle with the dot inside, which indicates an axis that is perpendicular to the plane of the L's. The axis of rotation is located either at the center or one end of a rod for each figure. Rank these L figures according to their moments of inertia about the indicated axes, from largest to smallest. Ignore the width of each rod but not the length.

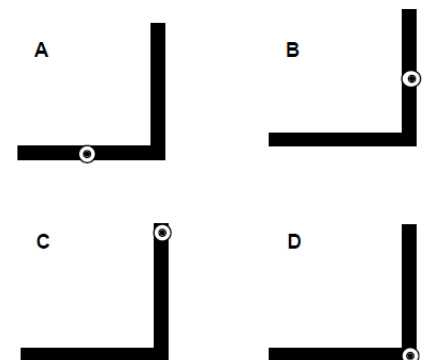

**Q22.** A light string attached to a mass  $m$  is wrapped around a pulley of mass  $m_p$  and radius  $R$ . If the rotational inertia of the pulley is  $\frac{1}{2}m_p R^2$ , derive an expression for the acceleration of the mass.

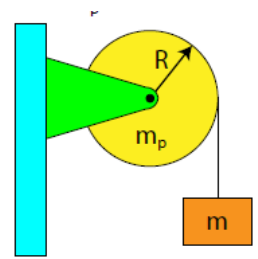

**Q23.** A merry-go-round on a playground with a rotational inertia of  $100 \text{ kg}\cdot\text{m}^2$  starts at rest and is accelerated by a force of  $150\text{N}$  at a radius of  $1\text{m}$  from its center. If this force is applied at an angle of  $90^\circ$  from the line of action for a time of  $0.5$  seconds, what is the final rotational velocity of the merry-go-round?

**Q24.** Three meter-long, uniform  $200\text{-g}$  bars each have a small  $200\text{-g}$  mass attached to them in the positions shown on the diagram below. A person grips the bars in the locations shown and attempts to rotate the bars in the directions shown. Calculate the rotational inertia for each bar.

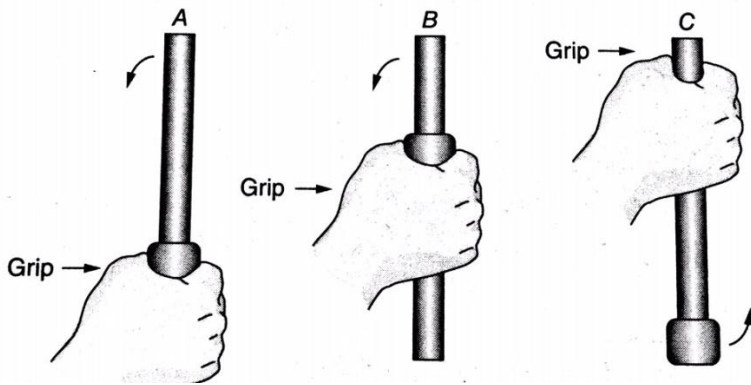

**Q25.** A weight is tied to a rope that is wrapped around a pulley. The pulley is initially rotating counterclockwise and is pulling the weight up. The tension in the rope creates a torque on the pulley that opposes this rotation. **a)** On the axes below, draw a graph of the angular velocity versus time for the period from the initial instant shown until the weight comes back down to the same height. Take the initial angular velocity as positive. **b)** Draw a graph of the angular acceleration versus time for the same time period.

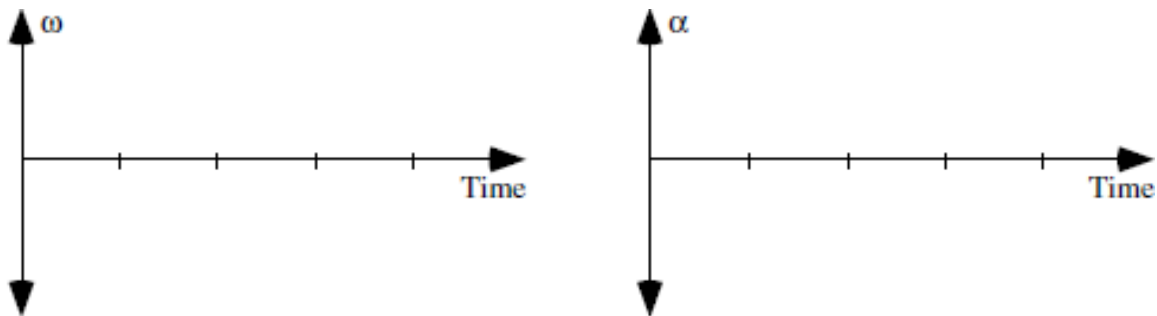

**Q26.** An angler balances a fishing rod on her finger as shown. If she were to cut the rod along the dashed line, would the weight of the piece on the left hand side be greater than, less than, or equal to the weight of the piece on the right-hand side? Explain using *both* qualitative and quantitative reasoning.



**Q27.** Visit the Unit 6 webpage on [www.PedersenScience.com](http://www.PedersenScience.com) and scroll down to the problem set for this unit. You will find an accompanying video of a wheel that is being accelerated by a falling 175-kg mass. Derive an expression for the rotational inertia of the wheel. Hint- you will need to look at the motion of the falling weight and the motion of the spinning wheel separately.

**FACT:** Recall that linear momentum is a vector quantity ( $\vec{p} = m\vec{v}$ ). Recall that impulse is equal to a change in momentum, which equals a force exerted for a period of time ( $J = \Delta p = F\Delta t$ ). The rotational analogue for the momentum is known as angular momentum ( $L = I\omega$ ). This vector describes how hard it is to stop (or start) a rotating object. Angular impulse is equal to a change in angular momentum, which equals a torque exerted for a period of time. ( $\Delta L = I\omega_f - I\omega_o = T\Delta t$ ).

**Q28.** A constant force is applied for a constant time at various points on the object shown below. If point C is the axis of rotation, rank the magnitude of the change of the object's angular momentum due to the force. Rank from the smallest to the largest.

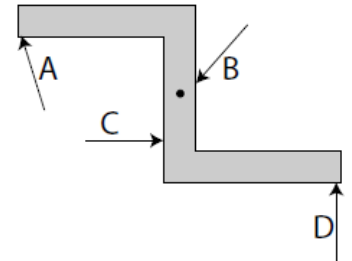

**FACT:** The law of conservation of angular momentum states that the product of an objects rotational inertia and angular velocity ( $L = I\omega$ ) about the center of mass is conserved in a closed system with no external torque. As rotational inertia increases, angular velocity decreases, and thus, they are inversely proportional. Angular momentum is conserved in nearly all collisions, as well as many other situations.

**Q29.** A disc (radius = 1 m) with a rotational inertia of  $1 \text{ kg}\cdot\text{m}^2$  spins about an axle through its center of mass with an angular velocity of 10 rad/s. A second disc (radius = 0.5 m), which is not turning, but has a rotational inertia of  $0.25 \text{ kg}\cdot\text{m}^2$  is slid along the axle until it makes contact with the first disc. If the discs stick together, what is their combined angular velocity?

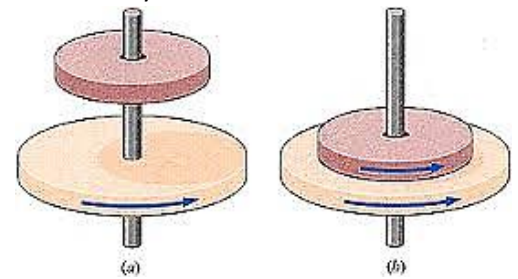

**Q30.** Sophia spins on a rotating pedestal with an angular velocity of 8 radians per second. Eric throws her an exercise ball, which increases her rotational inertia from  $2 \text{ kg}\cdot\text{m}^2$  to  $2.5 \text{ kg}\cdot\text{m}^2$ . What is Sophia's angular velocity after catching the exercise ball? (Neglect any external torque from the ball.)

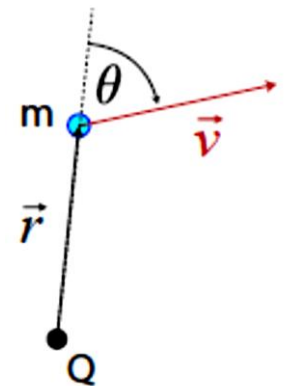

**FACT:** For a single point particle moving in a circle around an axis, its angular momentum is  $L = mvr$  ( $r$  = radius of circle). However, a single point particle that is moving in a straight line can also have angular momentum that is relative to the point of reference ( $L_Q = mvr \sin\theta$  or  $L_Q = m\omega r^2 \sin\theta$  or  $L_Q = pr \sin\theta$ ). The subscript of Q shows that the angular momentum is relative to point Q on the schematic to the right.

**Q31.** Four particles, each of mass  $M$ , move in the x-y plane with varying velocities as shown in the diagram. The velocity vectors are drawn to scale. Rank the magnitude of the angular momentum about the origin for each particle from largest to smallest.

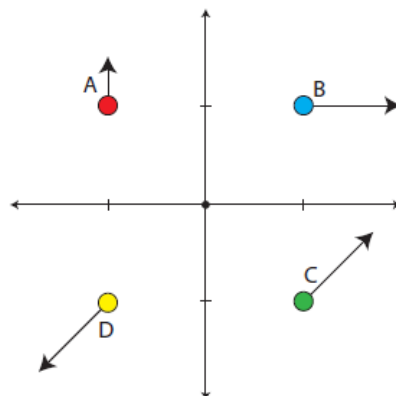



**Q32.** A uniform rod of mass  $M$  is at rest on a frictionless table. A ball of Play-doh with a mass  $\frac{M}{2}$  is moving to the left, as shown in the diagram. The ball of Play-doh collides and sticks to the rod. What is the speed of the center of mass of the rod-Play-doh system?

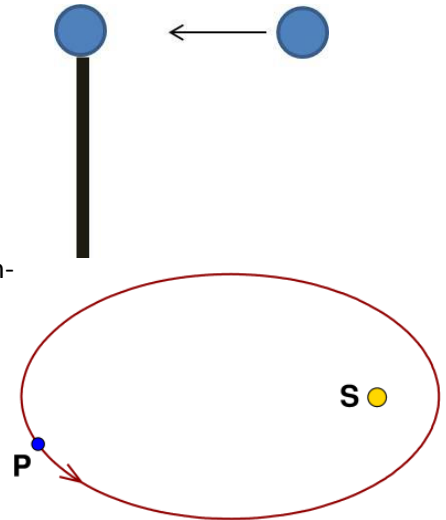

**Q33.** A planet (P) orbits the Sun (S) in an elliptical orbit. (a). Using qualitative reasoning, explain how to determine the torque exerted by the force of the Sun on the planet. (b). Using semiquantitative reasoning, explain how angular momentum is conserved in the Sun-planet system.

**FACT:** If an object exhibits both translational and rotational motion, the total kinetic energy of the object can be found by  $K_{\text{tot}} = \frac{1}{2} mv^2 + \frac{1}{2} I\omega^2$ . The units will be Joules.

**Q34.** A person rolls a bowling ball of mass 7 kg and radius 10.9 cm down a lane with a velocity of 6 m/s. Find the rotational kinetic energy of the bowling ball, assuming it does not slip. Find the total kinetic energy.

**Q35.** Sophia kicks a soccer ball which rolls across a field with a velocity of 5 m/s. What is the ball's total kinetic energy? The ball has a mass of 0.43 kg, a radius of 0.11 m, and it does not slip as it rolls. The rotational inertia of a hollow sphere is  $\frac{2}{3} MR^2$

**Q36.** An ice skater spins with a specific angular velocity. She brings her arms and legs closer to her body, reducing her rotational inertia to half its original value. What happens to her angular velocity? What happens to her rotational kinetic energy? Answer using semiquantitative reasoning.

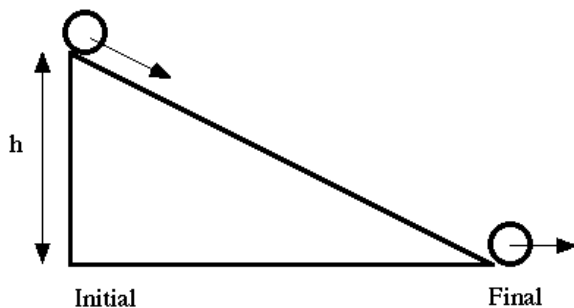

**FACT:** You can use the conservation of mechanical energy to solve rotational kinetic energy problems. Recall with conservative forces the total mechanical energy equals the potential energy (U) plus the kinetic energy (K). The major types of potential energy are springs and gravitational.

**Q37.** Find the speed of a disc of radius 0.5 meters and mass 2-kg at the base of the incline. The disc starts at rest and rolls down the incline with a height of 5 meters without slipping. The incline makes a  $20^\circ$  angle with the horizontal surface.

**FACT:** On occasion when using  $\Sigma T = I\alpha$  you may need to substitute  $Fr$  for torque or  $\omega_f - \omega_o / t$  for  $\alpha$ .

**Q38.** A hoop with rotational inertia  $I=0.1 \text{ kg}\cdot\text{m}^2$  spins about a frictionless axle with an angular velocity of 5.0 radians per second. At what radius from the center of the hoop should a force of 2.0 newtons be applied for 3 seconds in order to accelerate the hoop to an angular speed of 10 radians per second?

**Challenge Problems (39-42):** These problems are just for fun!

**Q39.** Two ropes, having tensions  $T_2$  and  $T_3$ , support a uniform 100-N beam and two weights. If the right weight has a mass of 25 kg and  $T_2$  has a tension of 500 N, calculate the tension in  $T_3$  as well as the mass of the unknown weight. 250 N; 40 kg

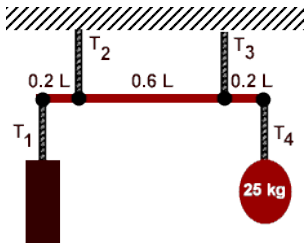

**Q40.** A 75-kg block is suspended from the end of a uniform 100-N beam. If  $\theta = 30^\circ$ , what are the values of  $T_2$  as well as the horizontal and vertical forces on the hinge?

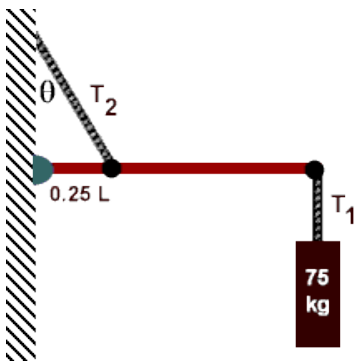

**Q41.** A uniform bar of mass  $m$  and length  $L$  extends horizontally from a wall. A supporting wire connects the wall to the bar's midpoint, making an angle of  $55^\circ$  with the bar. A sign of mass  $M$  hangs from the end of the bar. If the system is in static equilibrium and the wall has friction, determine the tension in the wire and the strength of the force exerted on the bar by the wall if  $m = 8$  kg and  $M = 12$  kg.

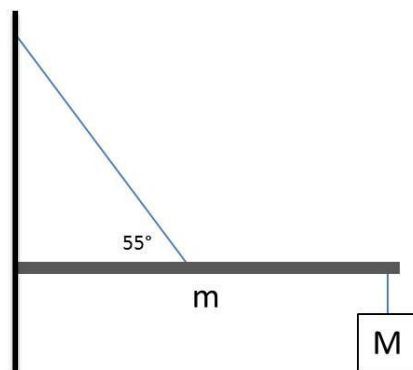

**Q42.** Two blocks are connected by a light string over a pulley of mass  $m_p$  and radius  $R$  as shown in the diagram. Derive an expression for the acceleration of mass  $m_2$  if  $m_1$  sits on a frictionless surface.

